



Model 100-308

Fire Alarm Pull Station

Hazardous, Non-Hazardous, Weatherproof, or Harsh Locations

The Model 100-308 Fire Alarm Pull Station is specifically designed for harsh industrial environments where weatherproofing and corrosion are issues.

The unit is rated for Class I Div. 2 Groups A,B,C,D,
Class I, Zone 2 Gr IIA, IIB, & IIC
Class II Div. 2 Groups F & G
NEMA Type 4, 4X, 13
24VDC, 2.5 amps Max

Enclosure is molded fiberglass reinforced polyester with stainless steel cover screws and mounting feet. Enclosure is molded in red and is UV stabilized for outdoor use.

Pull station is provided with 1 SPST NC hermetically sealed contact block. Contact is held in NO position by keeper pin.

Enclosure is easily drilled for a 3/4" conduit hub (provided) and mounting feet have a 1/4" hole.

The pull station is activated by a pull ring, and is reset by depressing the pushbutton and re-inserting pull ring.

Signage can be customized with up to 3 lines of 11 characters per line.



Product Detail

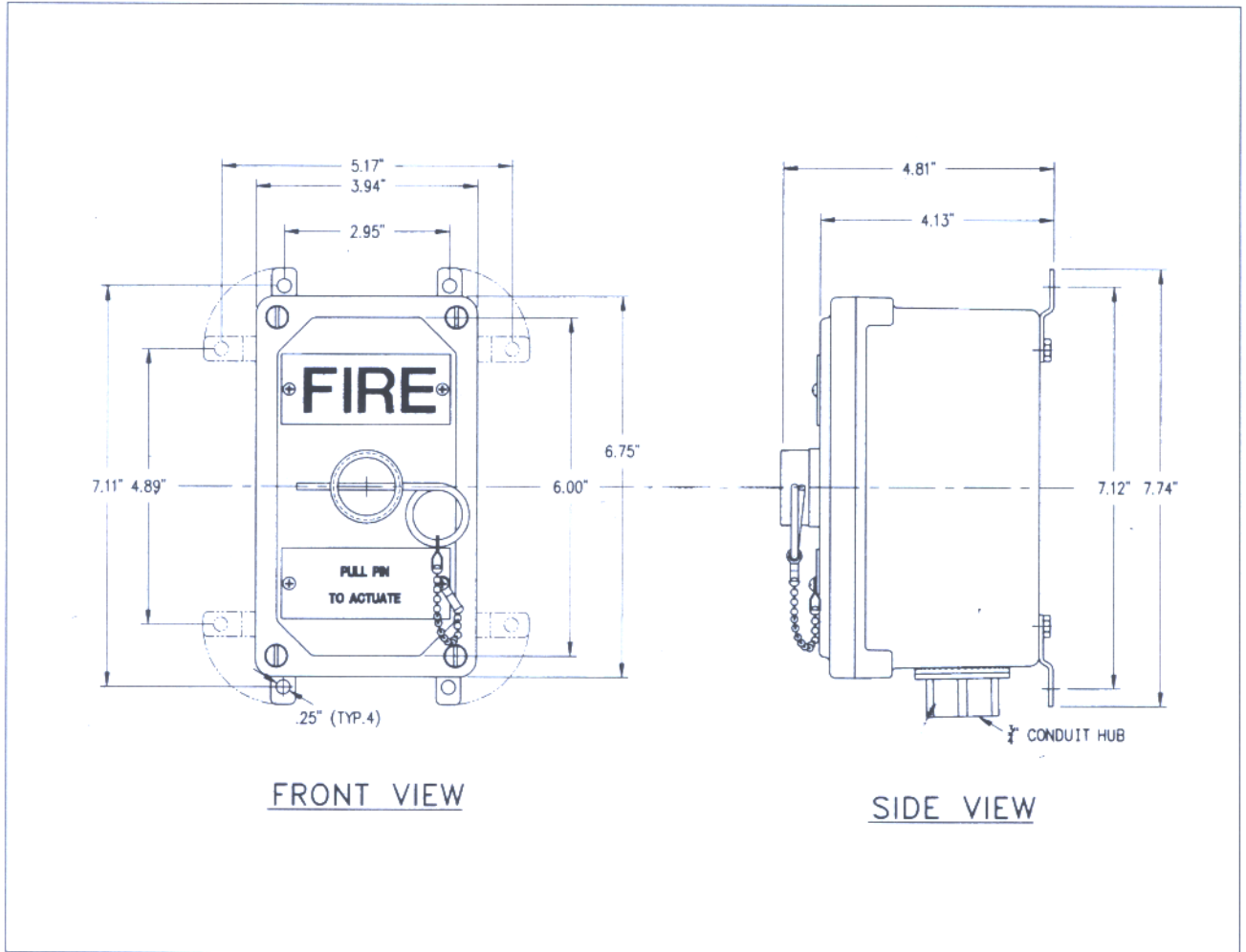

Specifications

Net Weight:	2 lbs.
Shipping Weight:	2.25 lbs.
Height:	6.74"
Width:	3.93"
Depth:	3.88"

Ordering Information

Standard:	Model #100-308 Signage: Pull Pin to Actuate
Custom:	Signage can be customized with up to 3 lines of 11 characters per line.

Wiring Detail

